



Just Art

AN ELEMENTARY ART DOCENT PROGRAM

CREATED BY: RACHEL A. DILLON



“Eagles Art has taught students about dozens of artists from across the globe. It’s a truly special program.”

- DAVID FRANKEL, PRINCIPAL AT GOLD RIDGE ELEMENTARY



Just Art

— AN ELEMENTARY
ART DOCENT PROGRAM



MY PHILOSOPHY AND PROGRAM

Art can give kids confidence to try something without fearing failure. Now more than ever, children need to be encouraged to think outside the box and recognize their individuality.

Just Art – An Elementary Art Docent Program is for children grades kindergarten to fifth. The program is a six-year art curriculum so students will never receive the same project twice. Gold Ridge Elementary School has been thriving with this program since 2014.

The program provides **six art docent lessons per school year**. Each one-hour art lesson is a two-part PowerPoint presentation.

PART ONE

An art history lesson to teach about one of the following:

- An artist (male or female, current or historical)
- Art Theory
- Cultural art
- A children's book author/illustrator

PART TWO

A step-by-step art project. Each academic year provides a variety of lessons that include a mix of mediums:

- Acrylic painting
- Watercolor painting
- Oil pastels
- Collage
- Colored pencils
- Crayons

To assist your school appointed volunteer art docent coordinator, Just Art provides:

- A summary sheet with an art materials supply list
- A list of California core art skills covered in the lesson
- A presentation to aid the art docent conducting the lesson

To make Just Art more powerful, I devote one evening per month to providing hands-on training for the art docents of your school to give them the confidence to teach the project, not to mention having a blast doing the art project themselves.

“I love this art program! It's absolutely wonderful. I even sit down and do the project with the students.”

- FOURTH GRADE TEACHER AT GOLD RIDGE ELEMENTARY



MY PHILOSOPHY AND PROGRAM



The PowerPoint deck contains extra notes to help the art docent. It also includes fun questions to engage the learners.

At times, younger students might need a little assistance with the background of a project, I have created handouts the docent can copy and distribute. This is useful when the project's focus is on painting and color-mixing.

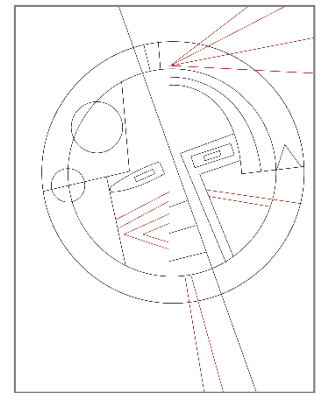

“Eagles Art is one of my favorite things I do at school. Every month I love to learn about a new artist and try to make a piece of art like theirs. It is so fun.”

- FRANK, A FIFTH-GRADER AT GOLD RIDGE ELEMENTARY.

SOME OF THE
ARTISTS
REPRESENTED

Henri Matisse

Claude Monet

Wyland

Bev Doolittle

Steve Jenkins

Frida Kahlo

Faith Ringgold

Leonardo Da Vinci

Marcus Pfister

Mary Cassatt

Salvador Dali

Claire Basler

Sandra Boynton

Gregory Kondos

Vivienne Williams

Vincent Van Gogh

Rene Margritte

Yayoi Kusama



Just Art

AN ELEMENTARY
ART DOCENT PROGRAM



RACHEL A. DILLON'S BIOGRAPHY

Rachel Dillon graduated from the University of Wisconsin, Madison in 1994, with a Bachelor of Science in Art, emphasizing in Graphic Design. She received a Master of Science in Instructional Design and Technology in 2022 from CSU Fullerton.

In 2009, her non-fiction children's book, "Through Endangered Eyes – a poetic journey into the wild," was published by Windward Publishing, an imprint of Finney Company. She both wrote and illustrated it.

Her book received an Eric Hoffer Honorable Mention award in 2010. Rachel has been a featured artist in "Wildscape Magazine," a contributing artist in gallery and museum exhibitions, and a speaker at Art Educator conventions and conferences. The Nature Conservancy commissioned Rachel to produce two paintings for them in 2015.

Rachel taught art and developed the art curriculum at Brighton Private Elementary School in Folsom from 2012-2015.

Rachel developed a six-year rotational Art Docent curriculum, comprised of six projects per year. Gold Ridge Elementary in Folsom has been utilizing the Just Art program since 2014.



"I have so much fun during the art docent training. It's an hour where I get to learn and try out the art project. It's so relaxing."

– Art Docent

FOR MORE INFORMATION, PLEASE EMAIL Art@RachelDillon.com

PRICING

\$2,000 per year includes six PowerPoint lessons, art supply lists, and six in-person art docent training sessions.

This can be renewed on an annual basis.

(Art supplies are purchased by the volunteer Art Docent coordinator.)

ARTIST/STYLE	PROJECT MEDIUMS
YEAR ONE	
Henri Matisse	Acrylic paint
Paul Klee	Oil pastel on black paper
Perspective - Growing Veggies	Watercolor and crayon
Dutch Flower Field	Oil pastel
Reflections in Nature	Colored pencils and watercolor
Romero Britto	Black marker and crayon
YEAR TWO	
Claude Monet	Oil pastels
Vincent Van Gogh	Oil pastels on black paper
Wyland	Watercolor with salt
Bev Doolittle	Colored pencils, black marker and crayon
Culture - Aboriginal Art	Acrylic Dot painting
Steve Jenkins & Eric Carle	Colored paper and glue
YEAR THREE	
Color Theory	Oil pastel on black paper
Frida Kahlo	Acrylic paint
Culture - Native American Art	Black, red, blue markers only
George Rodrigue	Watercolor and resistance crayon
Faith Ringgold	Collage, crayon, marker, cutout and glue
Leonardo Da Vinci	Colored pencils and oil pastels
YEAR FOUR	
Marcus Pfister	Acrylic paint and glue
Art History - Pictograms	Colored pencil and markers
Salvador Dali	Watercolor and black marker
Mary Cassatt	Oil pastels
Jasper Johns	Pencils, markers, crayons
Claire Basler	Watercolor, acrylic paint
YEAR FIVE	
Sandra Boynton	Colored pencils
Georgia O'Keefe	Crayons, colored pencils, glue
Pablo Picasso	Colored markers
Gregory Kondos	Acrylic paint
Vivienne Williams	Oil pastels, glue, paper
Color Theory - The Wave	Watercolor paint and crayon
YEAR SIX	
Rene Magritte	Markers, crayon and chalk
Wayne Thiebaud	Oil pastel
Mo Williams	Crayons, colored pencils, marker
Yayoi Kusama	Rock, acrylic paint
Helen Hardin	Acrylic paint, glue, sand
Wildlife art - Eagle	Watercolor, crayon